



## **Door Installation Instructions Owners Manual**

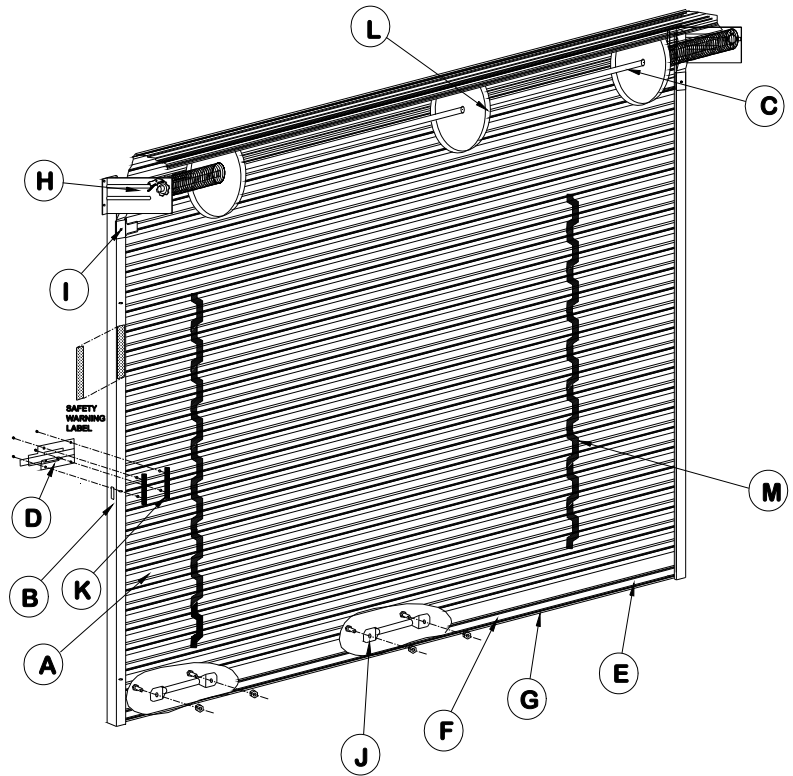
**P.O. BOX 1650, STATESVILLE, NC 28687  
PHONE: 704-872-2999, FAX: 704-872-3099**

**[www.betcoinc.com](http://www.betcoinc.com)**

**BETCO DOOR SYSTEMS  
INSTALLATION INSTRUCTION & OWNERS MANUAL**

## SAFETY TIPS

1. Read entire instructions carefully before installing door.
2. Door installer must perform installation, adjustments, and repairs.
3. Use proper lifting equipment and lifting procedures when installing door in opening.
4. All Betco Doors are now made with Tension Adjusters. Only trained installers are authorized to adjust tension on doors.
5. Do not cut retention band around door roll or unwrap protective wrap until instructions indicate.
6. Do not stand in door opening during operation of door.
7. Do not allow anyone other than authorized installers to adjust or install.
8. If door becomes inoperative or hard to operate, contact a qualified door installer.

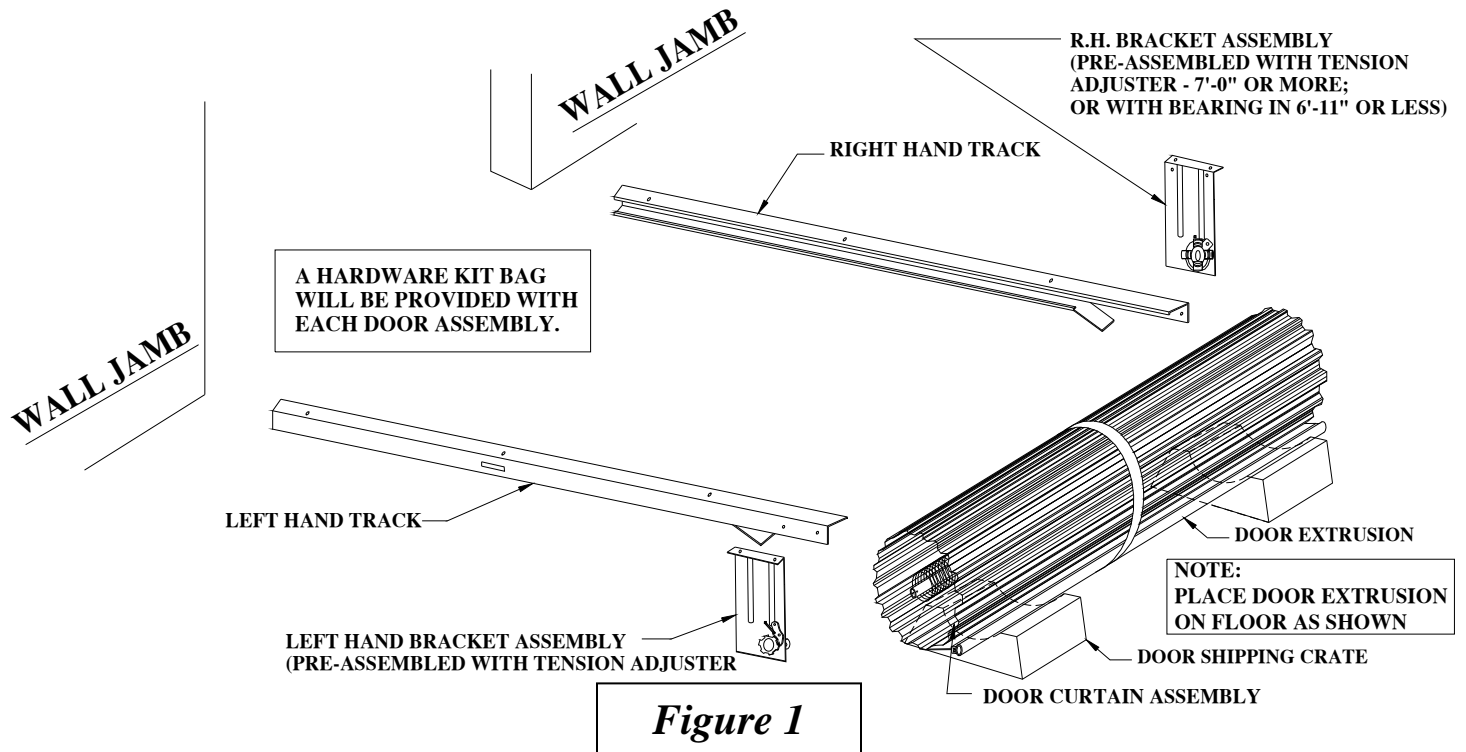


ITEM	DESCRIPTION	PART NUMBER	NOTES
A	DOOR CURTAIN	DP-6 OR DP-7 WIDTH, HEIGHT AND COLOR	ORDER BY OPENING WIDTH + 3.00", HEIGHT & COLOR
B	DOOR TRACK, LEFT DOOR TRACK, RIGHT	DTA-HEIGHT-DL DTA-HEIGHT-DR	ORDER BY DOOR OPENING HEIGHT +7.25"
C	DOOR AXLE ASSEMBLY	DAA-OPENING WIDTH-2D OR 3D +6.50"	ORDER BY DOOR OPENING WIDTH + 6.50"
D	DOOR LATCH KIT	D20055	STAINLESS STEEL W/ 4 STN.STL. BOLTS INSTALLED
E	DOOR ALUMINUM EXTRUSION ASSEMBLY	DX-OPENING WIDTH-AL +3.00"	ORDER BY DOOR OPENING WIDTH +3.00"
F	DOOR STIFFENER CHANNEL	DS-OPENING WIDTH-GL - 1.00"	ORDER BY DOOR OPENING WIDTH -1.00
G	DOOR ASTRAGAL	D20008	EDPM
H	DOOR BRACKET ASSEMBLY	D20100 W/ TA-LEFT & BRG-RIGHT OR D20101 W/ TA & BRG ON LEFT & RIGHT	TENSION ADJUSTER PRE-ASSEMBLED ON BRACKETS
I	DOOR STOP	D20002	PRE-PUNCHED FOR MAGNETIC DETECTOR
J	DOOR HANDLE	D20009	NONE
K	FELT TAPE STRIP	D20026	NONE
L	HARDWARE PACKAGE	STEEL, MASONRY OR WOOD CONSTRUCTION	ORDER BY BUILDING CONSTRUCTION
M	POLY DAMPENER	D20057 & D20058	NOISE DAMPENER AND PROTECTS PANELS FROM RUB DAMAGE

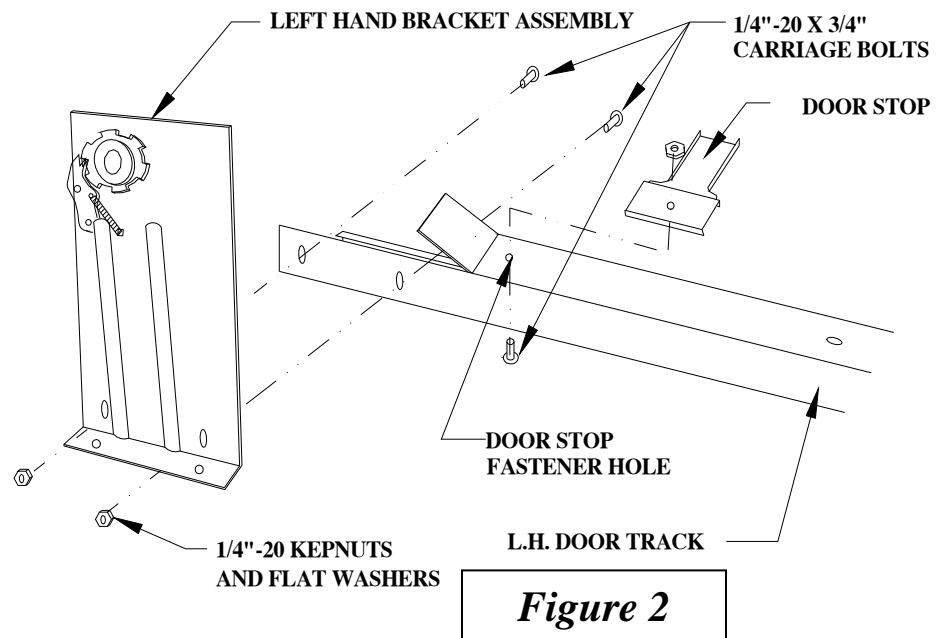
**STEP 1.** Check the door opening height and width to make sure it is the correct size door ordered. Make sure jambs are plumb and floor is level. (See Figure 6)

**STEP 2. DO NOT CUT BANDS OR UNWRAP PROTECTIVE COVER AROUND THE DOOR**

**AT THIS TIME.** Instructions to do so will come in Step 8. Position the door in front of the opening inside the building. Place crating under door curtain, which was shipped with doors for protection. (See Figure 1)

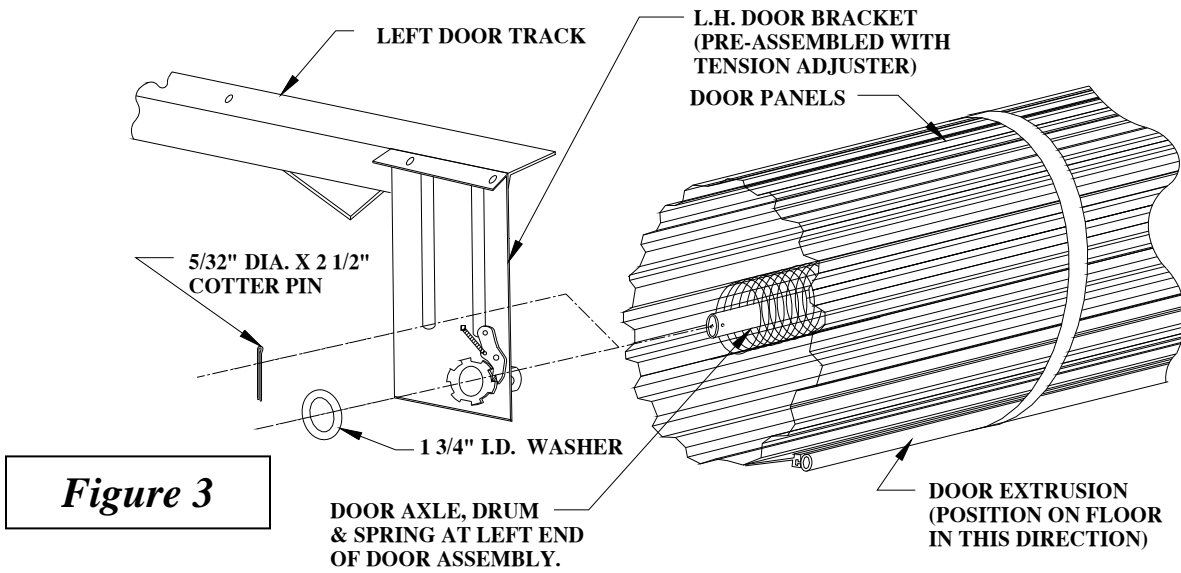


**STEP 3.** Attach door bracket to each track with fasteners shown in figure 2. Place the doorstop, bolt, and nut in each track. **DO NOT TIGHTEN.** The doorstop will be secured to track in STEP 9.



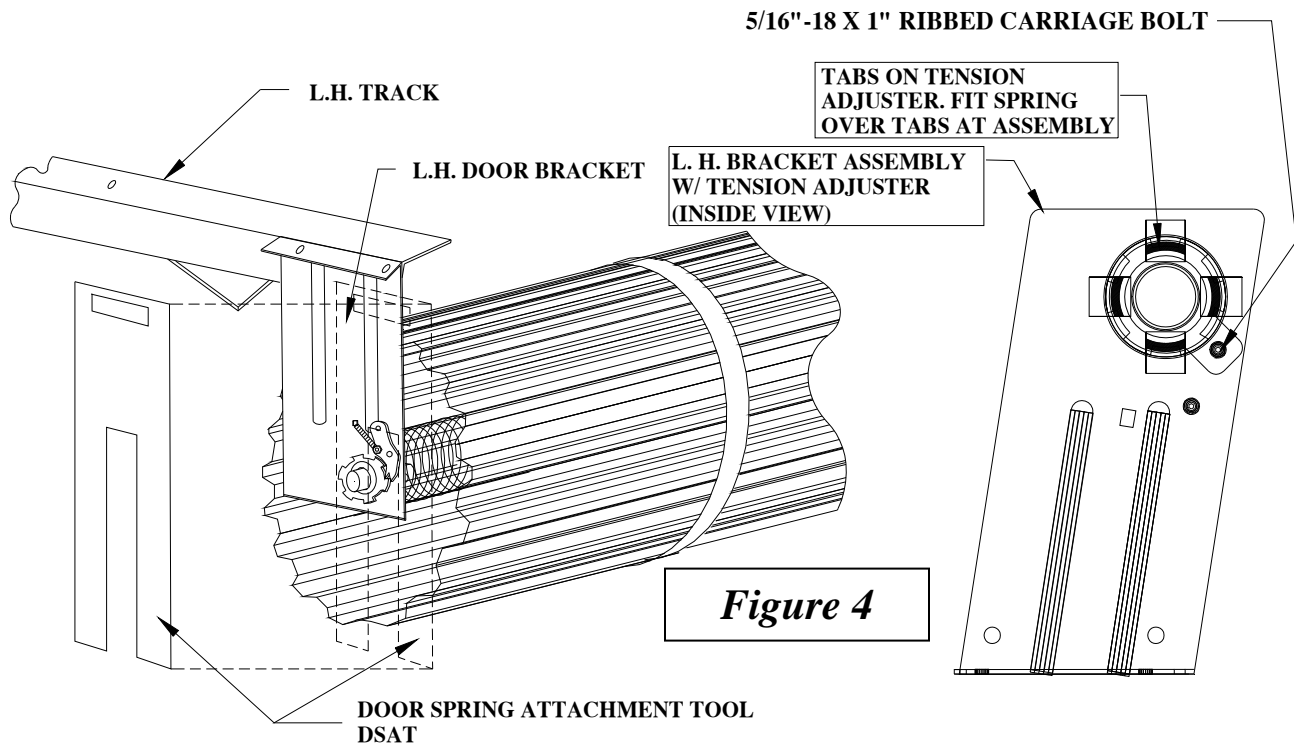
**STEP 4.** Slide DOOR BRACKET ASSEMBLY onto the end of the AXLE as shown in Figure 3. Slide AXLE WASHER in place over AXLE and install COTTER PIN into AXLE through the hole provided to

secure the DOOR BRACKET ASSEMBLY. (NOTE: Locate DOOR EXTRUSION as shown in Figure 3 for STEP 5). The location of the door extrusion is critical for proper mounting and spring tension.

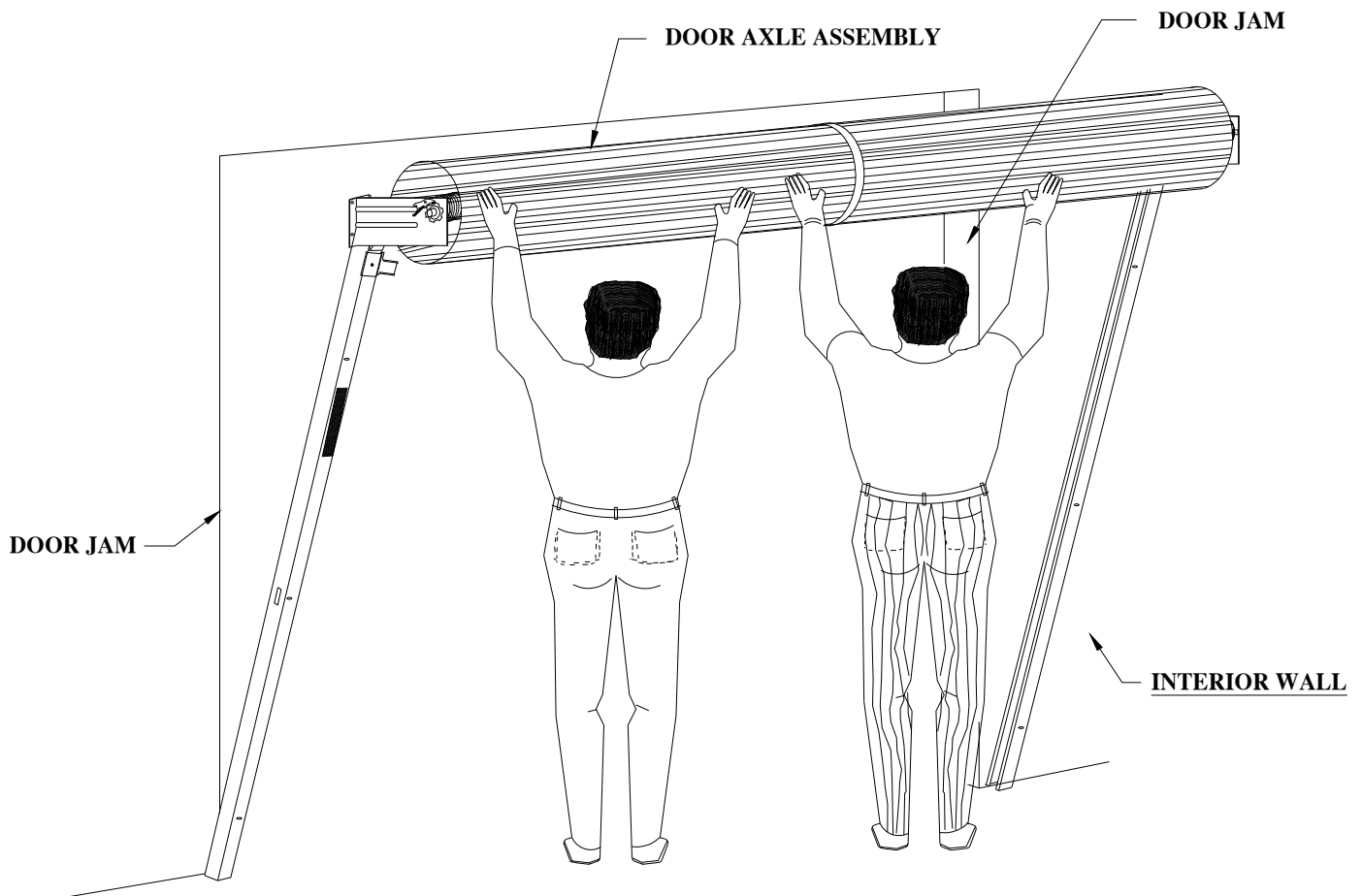


**Figure 3**

**STEP 5.** Pull spring to DOOR BRACKET ASSEMBLY; slide DOOR SPRING ATTACHMENT TOOL over AXLE near DOOR PANELS and release spring. Attach each spring end to each DOOR BRACKET ASSEMBLY over the tabs on TENSION ADJUSTER. Position the hook on spring over threaded stud and tighten nut with washer to threaded stud. (See Figure 4 below.)



**Figure 4**

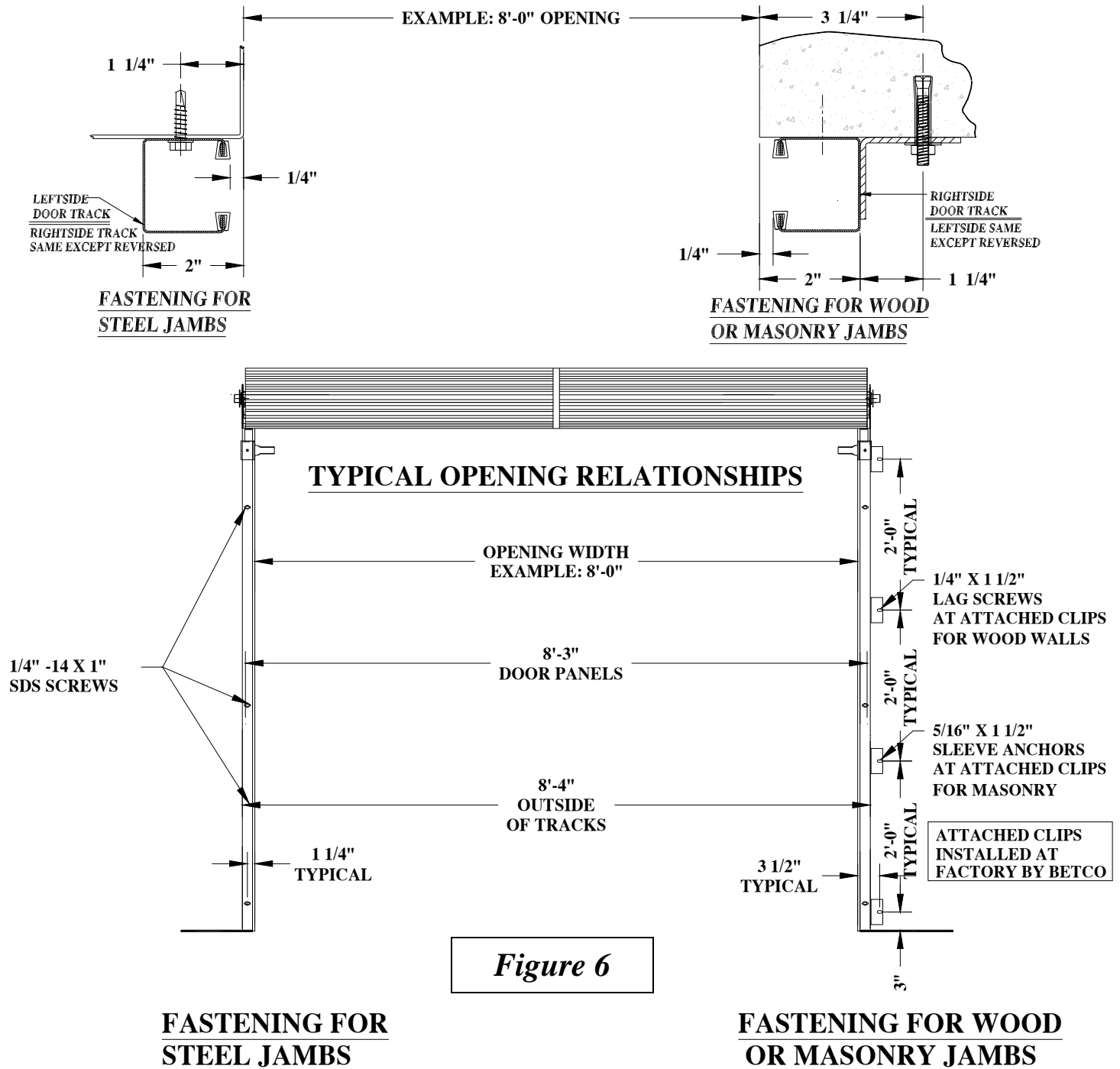


**STEP 6.** Position bottom of DOOR TRACKS against the back of wall columns; lift the DOOR AXLE ASSEMBLY to position against wall columns.

### **WARNING**

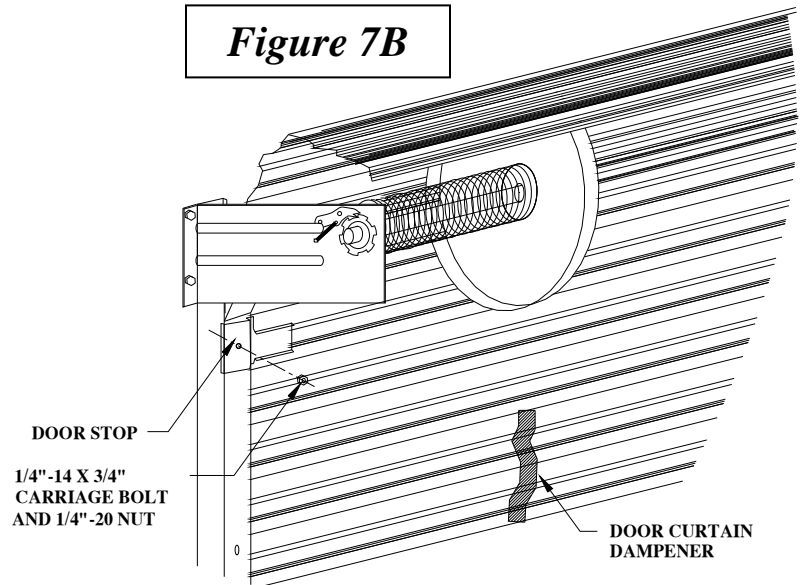
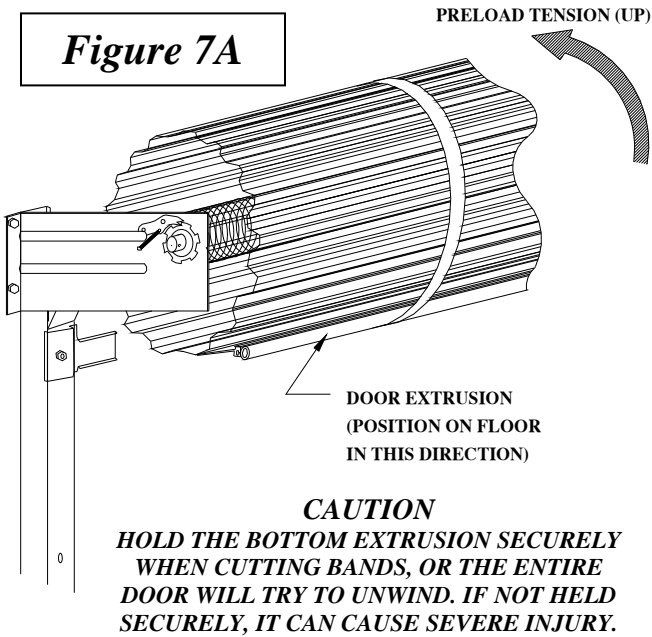
Lift the DOOR AXLE ASSEMBLY. Do not lift door by tracks. Door is not designed for a 1-person lift up installation. At least 2 installers are needed to lift and position the door. Lifting equipment should be used for large doors. Do not leave door unattended at anytime during installation to wall columns.

**STEP 7.** Attach the **RIGHT DOOR BRACKET ASSEMBLY** and **RIGHT TRACK** to the wall jamb with the type of fasteners that match the type of wall material (See Figure 6). Measure and position the outside edge of the **RIGHT TRACK**. Position the outside of **LEFT TRACK** the distance of door opening, plus 4" as shown in Figure 6 (Example: an 8'-0" opening should have a distance of 8'-4" outside of tracks.) Attach **LEFT DOOR BRACKET ASSEMBLY** and **LEFT TRACK** to jamb. Be sure the tracks are plumb and level. Remove protective wrap from door at this time but **do not cut or remove strapping.**

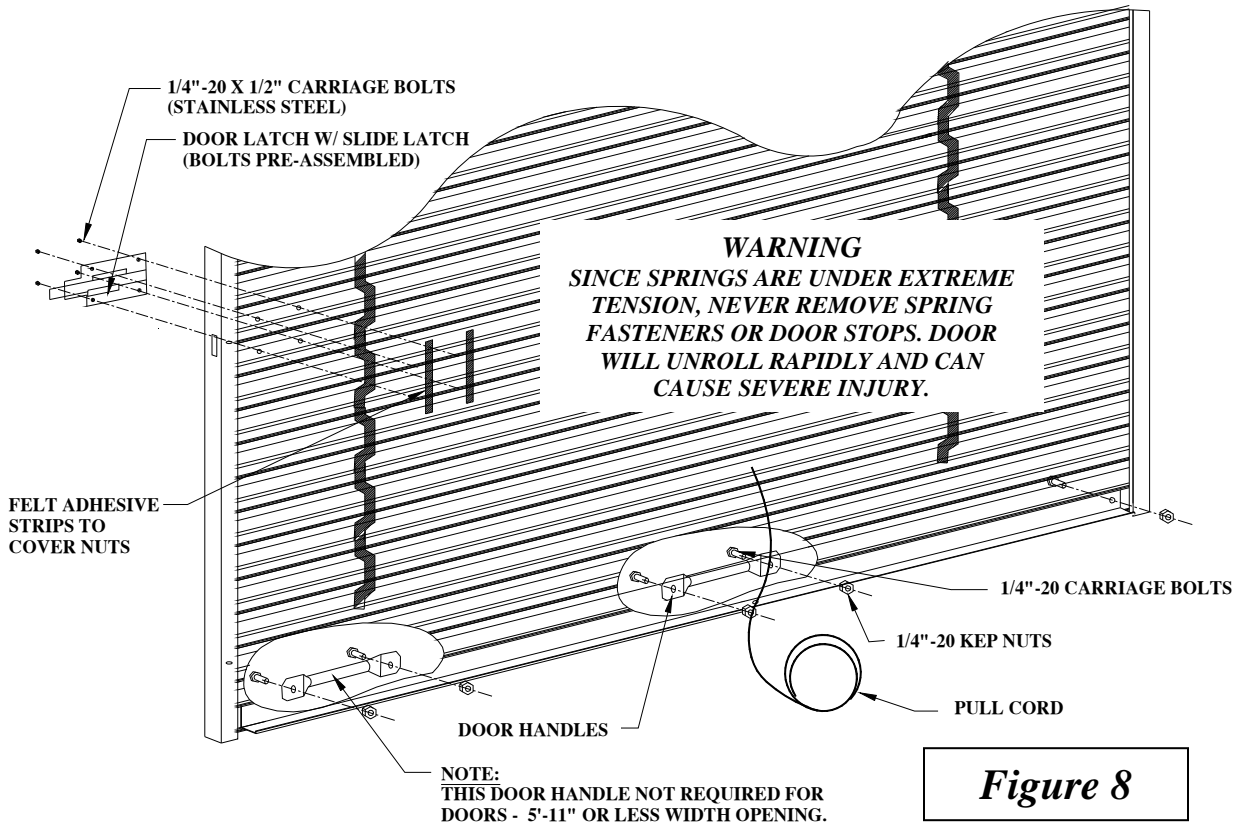


**Figure 6**

**STEP 8.** Pre-Tension the door springs by rotating the entire DOOR AXLE ASSEMBLY, at least 2 complete turns in the up direction, as shown in Figure 7A. While holding the BOTTOM EXTRUSION of the door securely, cut the straps around the door. Pull the BOTTOM EXTRUSION down into DOOR TRACKS to about 3 feet. (See Figure 7B) Have someone hold DOOR EXTRUSION until Step 9 is complete.

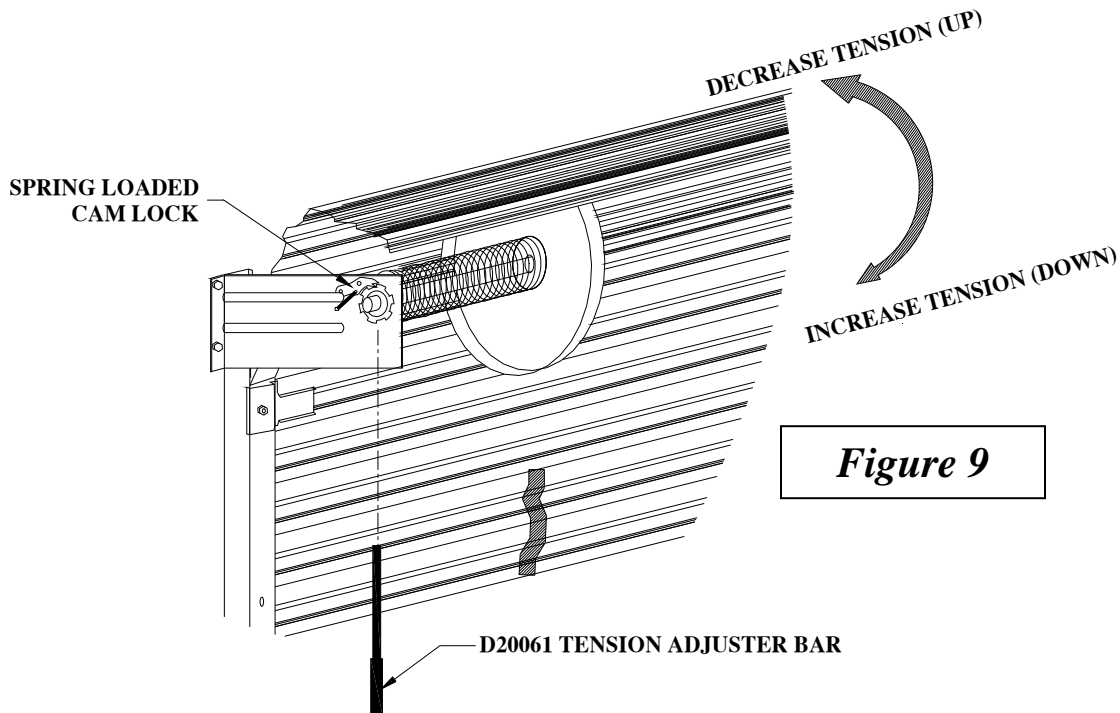


**STEP 9.** Install DOOR STIFFENER and DOOR HANDLES using 1/4" x 3/4" carriage bolts and kep nuts. (See Figure 8) Tighten DOOR STOPS with 1/4" x 3/4" carriage bolt and kep nut that was installed in STEP 3. (See Figure 7B) Install DOOR PULL CORD and DOOR LATCH ASSEMBLY. (See Figure 8)



## STEP 10. ADJUSTING SPRING TENSION USING TENSION ADJUSTER

If TENSION ADJUSTERS are on both sides of the door, TWO INSTALLERS will work in conjunction with each other to adjust tension. With the door in the closed position, fully insert TENSION ADJUSTER BAR into hole on each TENSION ADJUSTER. (See Figure 9) Pull down on the bar to increase tension. Make sure that each side has equal amount of clicks for proper operation. Lower and raise the door to test the spring balance. (Be sure to have adjuster bar and light, if inside dark building and the door need more tension to raise it.) If the door is easy to close, but hard to open, increase tension. If the door is hard to close, but easy to open, decrease tension. To decrease the tension you must place the adjuster bar in hole, lightly pull down until you can pull up on the spring loaded cam lock. (See Figure 9) Decrease tension one click at a time for safety.



**Doors with opening widths of 6'-11" or less, use one tension adjuster located on the left side. Doors with opening widths of 7'-0" or more use tension adjusters on each side.**

## STEP 11. PREVENTIVE MAINTENANCE

When doors are originally installed, door axles, springs and door tracks are lubricated to ensure smooth movement. Over time, these oils dry out and problems arise where rubber and plastic surfaces come in contact with metal doors and tracks. While units are vacant, we suggest doors be rolled down and springs and axles be lubricated with spray on lithium grease. At the same time, door tracks should be sprayed with clear silicone. Cans of lithium grease and silicone are available at any auto supply or home improvement store. These simple, preventive measures will make your doors work better with very little time and effort.